

Climate of the Past Discussions is the access reviewed discussion forum of *Climate of the Past*

An improved method for delta ^{15}N measurements in ice cores

F. S. Mani¹, P. Dennis¹, W. T. Sturges¹, R. Mulvaney², and M. Leuenberger³

¹School of Environmental Sciences, University of East Anglia, Norwich, UK

²British Antarctic Survey, Natural Environment Research Council, Cambridge, UK

³Climate and Environmental Physics, Physics Institute, University of Berne, Berne, Switzerland

Received: 20 December 2007 – Accepted: 20 December 2007 – Published: 8 February 2008

Correspondence to: W. T. Sturges (w.sturges@uea.ac.uk)

Published by Copernicus Publications on behalf of the European Geosciences Union.

CPD

4, 149–171, 2008

An improved method for delta ^{15}N measurements

F. S. Mani et al.

Title Page

Abstract

Introduction

Conclusions

References

Tables

Figures

⏪

⏩

◀

▶

Back

Close

Full Screen / Esc

Printer-friendly Version

Interactive Discussion



Abstract

The use of isotopic ratios of nitrogen gas ($\delta^{15}\text{N}$) trapped in ice cores as a paleothermometer to characterise abrupt climate changes is becoming a widespread technique. The versatility of the technique could be enhanced, for instance in quantifying small temperature changes during the last glacial period in Antarctic ice cores, by using high precision methods. In this paper, we outline a method for measuring $\delta^{15}\text{N}$ to a precision of 0.006‰ (1σ , $n=9$) from replicate ice core samples. The high precision results from removing oxygen, carbon dioxide and water vapour from the air extracted from ice cores. The advantage of the technique is that it does not involve correction for isobaric interference due to CO^+ ions. We also highlight the importance of oxygen removal from the sample, and how it influences $\delta^{15}\text{N}$ measurements. The results show that a small amount of oxygen in the sample can be detrimental to achieving an optimum precision in $\delta^{15}\text{N}$ measurements of atmospheric nitrogen trapped ice core samples.

1 Introduction

Ice cores provide a remarkable archive of past climatic conditions that could assist in understanding the mechanisms of climate change. The water isotopes of the ice ($\delta^{18}\text{O}_{\text{ice}}$ and $\delta\text{D}_{\text{ice}}$) and the isotopes of the thermally fractionated trapped gases such as $\delta^{15}\text{N}$ are used as indicators for local temperature changes. The temperature profile reconstructed from $\delta^{18}\text{O}_{\text{ice}}$ is influenced by variables other than temperature, such as shifts of moisture sources, storm tracks and seasonality of precipitation (Grachev and Severinghaus, 2005). The spatial linear relationship between surface temperature and $\delta^{18}\text{O}_{\text{ice}}$ is not valid for the glacial period and it tends to underestimate the surface temperature variations (Landais et al., 2005; Huber et al., 2006). The $\delta^{15}\text{N}$ method is an independent and a direct way of assessing past temperature variations and could be used as a calibration tool for the $\delta^{18}\text{O}_{\text{ice}}$ paleothermometer. The temperature profile reconstructed from $\delta^{15}\text{N}$ can be correlated to other gas records such as methane and

CPD

4, 149–171, 2008

An improved method for $\delta^{15}\text{N}$ measurements

F. S. Mani et al.

Title Page

Abstract

Introduction

Conclusions

References

Tables

Figures

◀

▶

◀

▶

Back

Close

Full Screen / Esc

Printer-friendly Version

Interactive Discussion



carbon dioxide as it overcomes the ice age-age problem (Huber et al., 2006).

The method of using the thermally fractionated isotopes of gases to reconstruct past temperatures was initially developed by Severinghaus et al., (1998), who showed that during an abrupt climate warming a temperature gradient develops in the firn column which causes the heavier isotopes to migrate to the bottom colder regions, and become locked in the bubbles, before the temperature of the ice column re-equilibrates. By correcting for the gravitational fractionation, the thermal isotope anomaly is calculated through $\delta^{15}\text{N}_{\text{excess}}$, where $\delta^{15}\text{N}_{\text{excess}}$ is expressed as $\delta^{15}\text{N} - \delta^{40}\text{Ar}/4 = (\Omega_N - \Omega_{\text{Ar}}/4) \Delta T$. The laboratory determined thermal diffusion sensitivity (Ω) links the thermal isotope anomaly to the temperature gradient in the firn, ΔT , which in turn is related to surface temperature variations by use of either a simple heat diffusion model (Severinghaus and Brook, 1999) or an ice densification model including heat and gas diffusion terms (Goujon et al., 2001).

The $\delta^{15}\text{N}$ method has been extensively used in characterising abrupt climate changes in Greenland ice cores, and has also found some applications in Antarctic ice cores, especially to evaluate large temperature changes during the transition from the Last Glacial Maximum (LGM). Evidence from abrupt climate changes during the last glacial period (such as the Dansgaard Oeschger events in Greenland ice cores) in Antarctica is scant (see Table 1). The $\delta^{15}\text{N}$ method is considered to be a reliable method for reconstructing past rapid climate events. However, this method is subjected to limitations arising from the assumptions in the model parameters regarding the convective zones and approximation of past accumulation rates, data resolution and, most critically, the precision of the method. The precision is the limiting factor in its application to assess abrupt climate changes in Antarctic ice cores due to the smaller magnitude of Southern Hemisphere temperature changes (Caillon et al., 2001; Blunier et al., 2007). In earlier studies (Table 1) the analytical precision level of $\delta^{15}\text{N}$ measurements was in the range of 0.02‰ (Severinghaus et al., 1998) to 0.05‰ (Leuenberger et al., 1999). More recently the standard deviations of replicate standards is reported to be 0.003‰ (Severinghaus et al., 2003) and a pooled standard deviation of 0.006‰

An improved method for $\delta^{15}\text{N}$ measurements

F. S. Mani et al.

Title Page

Abstract

Introduction

Conclusions

References

Tables

Figures

◀

▶

◀

▶

Back

Close

Full Screen / Esc

Printer-friendly Version

Interactive Discussion



has been reported for replicate ice cores samples (Landais et al., 2006a, b).

The recently published higher precision levels have been attained by accounting for the isobaric interference caused by the formation of CO^+ ions (which also have masses 28 and 29) in the source region of the mass spectrometer, and the influences of the O_2/N_2 ratios on the mass spectrometer source sensitivity. The procedure for the isobaric interference correction is outlined in Bender et al., (1994) and Sowers et al., (1989), who reported the magnitude of the correction to be 0.02‰ for each ppmV difference in the CO_2 concentration between the sample and the reference gas. Petrenko et al., (2006) removed CO_2 during their extraction, but oxygen removal was not considered. In this study we present an improved method for high precision $\delta^{15}\text{N}$ measurements in ice cores by stripping O_2 and CO_2 ; a procedure derived from the work of Mariotti (1983) on ambient air samples. The precision levels obtained, and the effects of oxygen on the precision level, will be discussed. The technique will then be used to measure $\delta^{15}\text{N}$ in ambient air, Antarctic firn air, and air extracted from Antarctic ice core samples from the Holocene period.

2 Experimental

2.1 Extraction method

A “wet” extraction method was employed to remove trapped gases from ~20 g of inner ice core sample. The surfaces of the ice samples were trimmed in an ice core laboratory at -25°C and placed in a pre-chilled glass extraction vessel, containing a magnetic stirrer. The extraction vessel was sealed with a Viton o-ring using a glass flange and a metal clamp. The effectiveness of the o-ring seal was tested by evacuating the extraction vessel to less than 20 Pa and isolating from the pump for 24 h; no significant increase in pressure was noted. The glass vessel was immersed in liquid nitrogen and ethanol mixture at $\sim -30^\circ\text{C}$ to keep it cold during the evacuation. The extraction vessel was attached to a vacuum manifold and the room air evacuated from the vessel for

An improved method for delta ^{15}N measurements

F. S. Mani et al.

Title Page

Abstract

Introduction

Conclusions

References

Tables

Figures

◀

▶

◀

▶

Back

Close

Full Screen / Esc

Printer-friendly Version

Interactive Discussion



20 min. During evacuation the pressure in the vessel reduced to ~ 20 Pa which is the vapour pressure of water over ice at $\sim -30^\circ\text{C}$. This continual flux of sublimed vapour assists in the evacuation of room air, and also cleans the surface of the ice sample of any gaseous contamination (Severinghaus et al., 2003).

5 After evacuation the vacuum tap on the lid of the extraction vessel was closed and isolated from the vacuum manifold. The vessel was placed in warm water to melt at least half of the ice sample, and was then placed on the magnetic stirrer plate to agitate the melt vigorously in order to accelerate the melting process. During melting the extraction vessel was attached to the extraction line (see Fig. 1) via Cajon Ultratorr fittings, and the extraction line evacuated to 8×10^{-4} Pa with a diffusion pump backed by
10 a rotary pump. Once the melting was complete the air was passed through a glass trap at -80°C (dry ice and ethanol slurry) to remove water. The gas was then expanded into a 600°C furnace containing copper granules (Aldrich, 10–40 mesh) for 10 min to remove oxygen.

15 During the oxygen removal process a dip tube was prepared to receive the sample. The sample tube was a $1/4'' \times 1.5$ m stainless steel tube with a Nupro metal bellows valve attached, evacuated to a pressure of 1×10^{-4} Pa before being immersed into a liquid helium dewar. After removal of oxygen the gas stream was then allowed into a second glass trap at -196°C (liquid nitrogen) for a further 5 min to remove CO_2 , after
20 which the vacuum valve downstream of the second glass trap was slightly opened so that the pressure upstream decreased by ~ 10 Pa/min, ensuring slow consistent flow across the furnace for complete removal of any residual oxygen in the sample. The gas was transferred into the dip tube immersed in the liquid helium dewar for 35 min, or until the pressure downstream decreased to 0 Pa on a $0-1 \times 10^5$ Pa gauge. After
25 collection the valves to the high vacuum pump and associated pressure gauge were opened, at which point the residual pressure in the extraction line was observed to be $\sim 1 \times 10^{-2}$ Pa.

While the gas was being cryopumped into the dip tubes, the sample flow through the furnace was controlled by metering the valve just immediately downstream of the

An improved method for delta ^{15}N measurements

F. S. Mani et al.

Title Page

Abstract

Introduction

Conclusions

References

Tables

Figures

◀

▶

◀

▶

Back

Close

Full Screen / Esc

Printer-friendly Version

Interactive Discussion



liquid nitrogen trap to increase the residence time of the sample in the furnace and so ensure essentially complete removal of oxygen. If the valve was fully opened the pressure upstream decreased very rapidly, and the oxygen was not removed completely in the furnace, resulting in an interference with the $\delta^{15}\text{N}$ measurements (see below).

5 Another potential source of error, resulting from sample fractionation, could occur if the sample was not completely collected in the dip tube. To investigate this the sample freezing time was increased to 50 min, and to 75 min, for which the residual pressure decreased to 8×10^{-3} , and 5×10^{-3} Pa respectively, but this did not affect the measured $\delta^{15}\text{N}$ values. This confirms that essentially all of the sample had been recovered in
10 the dip tubes, and that there were no fractionation effects during the extraction process (see Sect. 3.3).

This technique of removing oxygen using a copper reduction furnace has been previously applied to $^{15}\text{N}/^{14}\text{N}$ measurements in ambient air by Mariotti (1983), but silica gel was used in that study to trap N_2 gas at 77 K. We initially attempted to replicate this
15 procedure, but it resulted in a lower precision of 0.020‰ which is in agreement with the precision of 0.025‰ obtained in Mariotti's work. Further tests with silica gel tubes revealed that the samples were fractionated during the desorption stage, with the ratios becoming heavier by as much as 0.05‰ suggesting that the lighter fraction was being preferentially retained on silica gel. The silica gel tubes were heated to accelerate desorption of the lighter fractions, but it was still not successful. This unusual behaviour of
20 nitrogen isotopes trapped on silica gel remains unexplained.

2.2 Measurements

Once the dip tubes were equilibrated at room temperature for 2 h the re-expanded gas sample was measured for m/z 29/28 ratios on a SIRA Series II (VG Isogas Ltd)
25 dual inlet mass spectrometer. The sample was introduced into the sample bellows and equilibrated for 10 min, then the valve on the dip tube was closed. The pressure in both the reference and sample bellows were equalized by adjusting the corresponding bellows volumes. The mass spectrometer was operated in the "normal" reference/sample

An improved method for delta ^{15}N measurements

F. S. Mani et al.

Title Page

Abstract

Introduction

Conclusions

References

Tables

Figures



Back

Close

Full Screen / Esc

Printer-friendly Version

Interactive Discussion



**An improved method
for delta ¹⁵N
measurements**F. S. Mani et al.

switching mode, performing 12 cycles per run with an integration time of 15 s per cycle, and an inter-cycle delay of 20 s. If the internal precision of the measurement was $\geq 0.006\%$, then the analysis was repeated automatically. Each sample was analysed in duplicate or triplicate. Masses m/z 32 (O_2), 40 (Ar) and 44 (CO_2) were also monitored by peak jumping, which served as a diagnostic tool for rejecting any sample that showed higher mass 32 or 44 signals due to incomplete removal of O_2 or CO_2 respectively, or leakage during the extraction process. Monitoring mass 40 was also useful in identifying any potential leaks in the inlet system, and inspecting the possibility of reference drift in the reference gas (see below).

2.3 Reference gas

The reference gas was prepared by mixing commercial oxygen free nitrogen with pure argon in a 20 L round-bottomed flask fitted with 9 mm Louwers-Harpert valves fitted with Viton o-rings. The volume of the reference flask was calibrated and a 78:1 mixture of N_2 and Ar prepared, closely resembling the composition of the extracted and deoxygenated air samples. The 20 L flask was placed on its side in a box filled with insulating material, and the exit port fitted with a glass tube fixed to the valve extending to the middle of the flask to minimise any thermal fractionation. During an analysis the mass 40 beam signal in both the reference and the sample was similar, indicating that the reference gas was correctly prepared.

2.4 Normalization to atmospheric N_2 isotopic composition

Outside ambient air was used as a standard gas for $\delta^{15}N$ measurement in common with studies of this type. The air was collected in glass fingers fitted with vacuum 9 mm Louwers-Harpert valves with Viton o-rings. Prior to collection the glass fingers were prepared by evacuating to 10^{-4} Pa and then heated with a hot air gun to desorb any gases on the glass surfaces. The glass fingers were then evacuated to a pressure of 10^{-4} Pa while cooling to room temperature. The glass fingers were equilibrated with

[Title Page](#)[Abstract](#)[Introduction](#)[Conclusions](#)[References](#)[Tables](#)[Figures](#)[⏪](#)[⏩](#)[◀](#)[▶](#)[Back](#)[Close](#)[Full Screen / Esc](#)[Printer-friendly Version](#)[Interactive Discussion](#)

outside air for two hours. This sampling technique avoids any sample fractionation due to temperature gradients, insufficient flow, or pressure fluctuations.

The air samples are processed in exactly the same manner as the ice core samples, mimicking the exact process for ice core extraction to ensure that any minor fractionation effects, or contamination in the extraction process, would cancel out. At least one air sample was extracted and analysed on the instrument daily, and then the samples analysed on that particular day were normalized to this value.

2.5 Correction for pressure imbalance between sample and reference gas

In high precision dual inlet analysis it is important to ensure that the sample and reference gas pressure, capillary characteristics, and depletion rates are identical to minimise the effect of small pressure imbalances on the measured isotopic composition. During this study we carefully adjusted the capillary crimps to ensure identical flow characteristics through both the reference and sample sides of the inlet system. We also characterised the effect of small pressure imbalances by measuring the variation in the 29/28 ratio as a function of the major beam signal intensity. This is carried out by varying the gas pressure in the reference bellows over a factor of two. This is commonly referred to as a linearity test. For the analyses that we report here the change in the 29/28 ratio is less than 1 ppm per nA of the major beam current. This is equivalent to a change in $\delta^{15}\text{N}$ of 0.13‰ per nA of beam current. We analysed samples at a major beam signal strength of approximately 6 nA, and balanced the sample and reference signals to significantly better than 1%. Thus any correction needed due to an initial pressure imbalance was less than 0.007‰ and could be ignored.

Finally, after balancing the sample and reference gas beams, the variable volume bellows were isolated from the carefully matched volumes (0.2 mL) in the sample and reference valve blocks. This ensured that the measurements were made with identical gas depletion rates with matched signals throughout the measurement period.

An improved method for delta ^{15}N measurements

F. S. Mani et al.

Title Page

Abstract

Introduction

Conclusions

References

Tables

Figures

◀

▶

◀

▶

Back

Close

Full Screen / Esc

Printer-friendly Version

Interactive Discussion



3 Results and discussions

3.1 Zero enrichment experiment

A zero enrichment experiment was conducted by expanding the reference gas into both bellows. This test reflects any fractionation of sample or reference en route to the source, and also assesses any leaks in the inlet system. The mean measured zero enrichment was $0.001 \pm 0.002\%$ ($n=7$). Hence the zero enrichment test confirms the satisfactory functioning of the mass spectrometer.

3.2 Precision

Precision was determined as the reproducibility of the analysis of replicate ambient air samples, and also from ice samples collected from similar depths during the Holocene period. The climate during the recent Holocene period has been relatively stable and as a result the $\delta^{15}\text{N}$ in these samples should be almost invariant, and so should allow a measure of the reproducibility of the technique. The ambient air samples were collected simultaneously, then subjected to the entire extraction and analytical procedure, resulted in a precision of 0.003% (1σ , $n=7$). These air samples were analysed on seven different days, and consequently the precision obtained represents any instrumental or reference drift over one week.

Reproducibility tests on Holocene ice core samples were carried out on a 55 cm length of ice core from Berkner Island, Antarctica (79°S , 45°W). Ten samples from a depth range of 451.55–452.10 m ($\sim 3950 \pm 50$ years BP) with a depth resolution of 2.5–7.5 cm were measured, and one measurement rejected due to procedural error. The precision of these measurements was 0.006% (1σ , $n=9$). In addition, seventeen more samples from a depth of 446.60–562.68 m were analysed, and values in the range of 0.209–0.228‰ were obtained with $1\sigma=0.006\%$. These measurements enhance the confidence in the method because the $\delta^{15}\text{N}$ values obtained were similar, within the error limit, to those observed at the bottom of the firn layer (see Fig. 2) at the same

Title Page

Abstract

Introduction

Conclusions

References

Tables

Figures

◀

▶

◀

▶

Back

Close

Full Screen / Esc

Printer-friendly Version

Interactive Discussion



location.

3.3 Testing for fractionation effects during the extraction procedure

To investigate if the extraction process would fractionate the samples, the reference gas was subjected to the entire extraction process, and then measured against the same reference gas. The reference gas was expanded into 6 glass vials. Five samples were processed through the extraction line whereas one sample was analysed without any prior treatment and acted as a reference point. A value of $0.005 \pm 0.004\%$ was obtained for the sample without any treatment, and values in the range of $0.003\text{--}0.007\%$ were obtained for the samples that underwent the complete extraction process. The absence of any significant difference between the values precludes any possibility of sample fractionation during the extraction process. In addition, the values are on either side of the 0.005% reference point indicating a lack of systematic bias in the extraction procedure.

3.4 Long term stability

To gauge any reference gas drift, firm air samples with known nitrogen isotopic composition were analysed on different days and the results are displayed in Table 2. The results for 0 and 12 m depth samples analysed on different occasions shows that the variability induced due to reference drift, instrumental drift, and sample processing is very small and is in the order the overall procedural error.

3.5 Influence of oxygen on $\delta^{15}\text{N}$ measurements

To investigate the influence of oxygen on the measured nitrogen isotope composition we adopted an experimental strategy in which air samples were analysed both with oxygen present and after oxygen was removed (see Table 3). The results clearly show that when oxygen is present the measured $\delta^{15}\text{N}$ composition of samples has an apparent enrichment of between 0.8 and 1% . Sowers et al. (1989) have reported a similar

An improved method for delta ^{15}N measurements

F. S. Mani et al.

Title Page

Abstract

Introduction

Conclusions

References

Tables

Figures

◀

▶

◀

▶

Back

Close

Full Screen / Esc

Printer-friendly Version

Interactive Discussion



effect when measuring $\delta^{15}\text{N}$ of air samples using air as reference gas in the mass spectrometer. Their observed change of 0 to 0.004‰ in $\delta^{15}\text{N}$ per ‰ change in $\delta(\text{O}_2/\text{N}_2)$ is consistent with the magnitude of change observed in this study. They were unable to draw defensive conclusions regarding the origin of this variation.

In this study samples that were not subjected to oxygen removal process had the analyte gas composition of approximately 78% N_2 , 21% O_2 and 1% Ar. However, enrichment in the measured $\delta^{15}\text{N}$ composition of samples at much lower oxygen concentrations is also observed. In Fig. 3 we plot the difference ($\Delta\delta^{15}\text{N}$) between the expected $\delta^{15}\text{N}$ and the measured $\delta^{15}\text{N}$ compositions for a range of samples (modern and Holocene air) as a function of the $m/z=32$ ($\text{I}(\text{O}_2)$) ion beam intensity. Enrichment starts to become significant at oxygen concentrations 10^4 times lower than in air. The functional dependency of $\Delta\delta^{15}\text{N}$ on $\text{I}(\text{O}_2)$ is of the form $\Delta\delta^{15}\text{N} \propto \text{I}(\text{O}_2)^{1/2}$.

The most likely cause of the apparent enrichment in $\delta^{15}\text{N}$ is isobaric interference of CO with N_2 . CO has isotopic species at $m/z=28$ ($^{12}\text{C}^{16}\text{O}$), 29 ($^{13}\text{C}^{16}\text{O}$) and 30 ($^{12}\text{C}^{18}\text{O}$) with isotopic ratios of approximately 1% (29/28) and 0.2% (30/28). Assuming similar ionisation efficiencies for N_2 and CO then a mixing ratio of just 7.6×10^{-4} for CO in N_2 is all that is required to cause a 1‰ enrichment of the 29/28 ratio and hence the measured $\delta^{15}\text{N}$ composition. Carbon monoxide and hydrogen are the most common residual gases in clean vacuum systems. Moreover, in the presence of oxygen, CO is readily formed by oxidation of impurity carbon in tungsten filaments and their supports (Brion and Stewart, 1968; Singleton, 1966). It has also been suggested that atomic oxygen, desorbed from a hot tungsten filament, can interact with the walls of a vacuum chamber to produce CO (Singleton, 1966).

The intensity of the $m/z=44$ peak also increases with oxygen content of the analyte gas. This is shown in Fig. 4. It is tempting to suggest that the rise in the mass 44 signal is the result of the homogeneous gas phase reaction at the ion source and ion gauge filaments (Singleton, 1966):

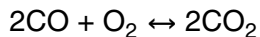

(R1)

An improved method for $\delta^{15}\text{N}$ measurements

F. S. Mani et al.

Title Page

Abstract

Introduction

Conclusions

References

Tables

Figures

◀

▶

◀

▶

Back

Close

Full Screen / Esc

Printer-friendly Version

Interactive Discussion



However, Leuenberger et al. (2000) show that, rather than CO₂, the major component of the $m/z=44$ beam is N₂O resulting from the reaction:



They observed an increase in signal only when both nitrogen and oxygen are present. When analysing pure oxygen they see no change in the $m/z=44$ signal.

It is unlikely that isotopic fractionation during production of N₂O according to this reaction can account for the apparent enrichment of ¹⁵N in N₂. Maximum $m/z=44$ intensities for air samples containing oxygen are just 5×10^{-13} A and are some 10⁴ times smaller than the N₂ beam intensity at $m/z=28$. An unrealistically large isotopic fractionation of 10,000‰ between N₂ and N₂O would be required to produce 1‰ enrichment in the 29/28 ratio.

We conclude that when oxygen is present, measured $\delta^{15}\text{N}$ compositions of nitrogen are enriched due to CO production in both the ion source and the walls of the mass spectrometer. This contribution of oxygen to the isobaric interference at $m/z=28$ and 29 is not accounted for when making the usual CO⁺ correction in which the magnitude of the correction is based on the CO₂ content of the sample. This may be based on the assumption that if the sample and reference gases have similar oxygen contents then the oxygen effect will be cancelled out. However, our results show that small differences in the oxygen content of samples and reference gases will have a measurable effect on the 29/28 ratio and, hence the measured nitrogen isotope composition.

Another feature, shown in Table 3, is the degree of reproducibility obtained between samples measured with and without oxygen stripping. Internal precisions of single measurements are typically in the range 0.001 to 0.006‰ for samples with the oxygen removed, whereas the samples with oxygen have lower internal precisions in the range 0.007 to 0.08‰. That is an order of magnitude lower in precision. Reproducibility between replicate samples lies in the range 0.001 to 0.003‰ with oxygen removed, compared to 0.07 to 0.13‰ for samples with oxygen. Clearly oxygen affects both the accuracy and precision of measurements.

An improved method for delta ¹⁵N measurements

F. S. Mani et al.

Title Page

Abstract

Introduction

Conclusions

References

Tables

Figures

◀

▶

◀

▶

Back

Close

Full Screen / Esc

Printer-friendly Version

Interactive Discussion



4 Conclusions

We developed and validated an improved method for $\delta^{15}\text{N}$ measurements in ice cores. The procedure adopted in Marriotti's work was modified to include helium cryopumping, and high oxygen removal efficiency by controlling sample flow across a copper furnace.

Furthermore a standard that had identical gas composition to the extracted air sample was prepared and used in the experiments. Overall procedural precisions (extraction and analysis) of 0.003‰ for replicate ambient air samples, and 0.006‰ for replicate ice core samples were obtained. This high precision arises from stripping oxygen, carbon dioxide and water vapour from the samples. The technique developed does not involve any isobaric interference corrections, and therefore eliminates the need for quantifying the carbon dioxide concentrations in ice cores with associated analytical uncertainties. This direct method for $\delta^{15}\text{N}$ measurements could be useful in assessing the magnitudes of temperature changes for the succession of abrupt climate events during the last glacial period in Antarctic ice cores. Such climate events are yet to be studied due to complexities in the existing method. The method developed here could potentially resolve the precision issue, and hence lead to a direct comparison of reconstructed temperature records based on $\delta^{15}\text{N}$ anomalies after synchronization of those gas ice core records from the two hemispheres using high resolution methane measurements.

Acknowledgements. This work was supported by the CEC within the Marie Curie Early Stage Researcher Training: Fellowships in Antarctic Air Sea Ice Science (FAASIS) project (contract # MEST-CT-2004-514159). We would like to thank A. Marca-Bell and J. Kaiser for helpful discussions regarding the methodology.

References

Bender, M. L., Tans, P. P., Ellis, J. T., Orchardo, J., and Habfast, K.: A high precision isotope ratio mass spectrometry method for measuring the O_2/N_2 ratio of air, *Geochim. Cosmochim. Ac.*, 58(21), 4751–4758, 1994.

CPD

4, 149–171, 2008

An improved method for delta ^{15}N measurements

F. S. Mani et al.

Title Page

Abstract

Introduction

Conclusions

References

Tables

Figures

◀

▶

◀

▶

Back

Close

Full Screen / Esc

Printer-friendly Version

Interactive Discussion



- Brion, C. E. and Stewart, W. B.: Mass Spectrometric Analysis of Oxygen, *Nature*, 217, 946, 1968.
- Blunier, T., Spahni, R., Barnola, J.-M., Chappellaz, J., Loulergue, L., and Schwander, J.: Synchronization of ice core records via atmospheric gases, *Clim. Past*, 3, 325–330, 2007, <http://www.clim-past.net/3/325/2007/>.
- 5 Caillon, N., Severinghaus, J. P., Barnola, J.-M., Chappellaz, J., Jouzel, J., and Parrenin, F.: Estimation of temperature change and of gas age-ice age difference, 108 kyr B. P., at Vostok, Antarctica, *J. of Geophys. Res.*, 106(D23), 31 893–31 901, 2001.
- Grachev, A. M. and Severinghaus, J. P.: A revised $+10 \pm 4^\circ\text{C}$ magnitude of the abrupt change in Greenland temperature at the Younger Dryas termination using published GISP2 gas isotope data and air thermal diffusion constants, *Quaternary Sci. Rev.*, 24, 513–519, 2005.
- 10 Goujon, C., Barnola, J.-M., and Ritz, C.: Modeling the densification of polar firn including heat diffusion: application to close-off characteristics and gas isotopic fractionation for Antarctica and Greenland sites, *J. Geophys. Res.*, 108(D24), 4792, doi:10.1029/2002JD003319, 2003.
- 15 Huber, C., Leuenberger, M., Spahni, R., Flückiger, J., Stocker, T. F., Johnsen, S., Landais, A., and Jouzel, J.: Isotope Calibrated Greenland temperature record over Marine Isotope Stage 3 and its relation to CH_4 , *Earth Planet. Sci. Lett.*, 243, 504–514, 2006.
- Landais, A., Caillon, N., Severinghaus, J., Barnola, J. M., Goujon, C., Jouzel, J., and Masson-Delmotte, V.: Analyse isotopique de l'air piégé dans la glace pour quantifier les variations de temperature, *C. R. Geosci.*, 336, 963–970, 2004a.
- 20 Landais, A., Caillon, N., Goujon, C., Grachev, A. M., Barnola, J. M., Chappellaz, J., Jouzel, J., Masson-Delmotte, V. and Leuenberger, M.: Quantification of rapid temperature change during DO event 12 and phasing with methane inferred from air isotopic measurements, *Earth Planet. Sci. Lett.*, 225, 221–232, 2004b.
- 25 Landais, A., Barnola, J. M., Masson-Delmotte, V., Jouzel, J., Chappellaz, J., and Caillon, N.: A continuous record of temperature evolution over a sequence of Dansgaard-Oeschger events during Marine Isotopic Stage 4 (76 to 62 kyr BP), *Geophys. Res. Lett.*, 31, L22211, doi:10.1029/2004GL021193, 2004c.
- Landais, A., Jouzel, J., Masson-Delmotte, V., and Caillon, N.: Large temperature variations over rapid climatic events in Greenland: a method based on air isotopic measurements, *C. R. Geosci.*, 337, 947–956, 2005.
- 30 Landais, A., Masson-Delmotte, V., Jouzel, J., Raynaud, D., Johnsen, S., Huber, C., Leuenberger, M., Schwander, J., and Minster, B.: The glacial inception as recorded in the NorthGrip

**An improved method
for delta ^{15}N
measurements**F. S. Mani et al.

Title Page

Abstract

Introduction

Conclusions

References

Tables

Figures

◀

▶

◀

▶

Back

Close

Full Screen / Esc

Printer-friendly Version

Interactive Discussion



**An improved method
for delta ¹⁵N
measurements**F. S. Mani et al.

[Title Page](#)[Abstract](#)[Introduction](#)[Conclusions](#)[References](#)[Tables](#)[Figures](#)[⏪](#)[⏩](#)[◀](#)[▶](#)[Back](#)[Close](#)[Full Screen / Esc](#)[Printer-friendly Version](#)[Interactive Discussion](#)

Greenland ice core: timing, structure and associated abrupt temperature changes, *Climate Dynam.*, 26, 273–284, 2006a.

Landais, A., Barnola, J. M., Kawamura, K., Caillon, N., Delmotte, M., Ommen, T. V, Dreyfus, G., Jouel, J., Masson-Delmotte, V., Minster, B., Freitag, J., Leuenberger, M., Schwander, J.,
5 Huber, C., Etheridge, D., and Morgan, B.: Firn-air $\delta^{15}\text{N}$ in modern polar sites and glacial-interglacial ice: a model-data mismatch during glacial periods in Antarctica?, *Quaternary Sci. Rev.*, 25, 49–62, 2006b.

Lang, C., Leuenberger, M., Schwander, J., and Johnsen, S.: 16°C Rapid Temperature Variation in Central Greenland 70 000 Years Ago, *Science*, 286, 934–937, 1999.

10 Leuenberger, M. C., Lang, C., and Schwander, J.: Delta ¹⁵N measurements as a calibration tool for the paleothermometer and gas-ice age differences: A case study for the 8200 B. P. event on GRIP ice, *J. Geophys. Res.*, 104, 22 163–22 170, 1999.

Leuenberger, M. C., Nyfelder, P., Moret, H. P., Sturm, P., Indermuhle, A., and Schwander, J.:
15 CO₂ concentration measurements on air samples by mass spectrometry, *Rapid Comm. Mass Sp.*, 14(16), 1552–1557, 2000.

Mariotti, A.: Atmospheric nitrogen is a reliable standard for natural abundance measurements, *Nature*, 303, 685–687, 1983.

Petrenko, V. V., Severinghaus, J. P., Brook, E. J., Reeh, N., and Schaefer, H.: Gas records from the West Greenland ice margin covering the Last Glacial Termination: a horizontal ice core,
20 *Quaternary Sci. Rev.*, 25, 865–875, 2006.

Severinghaus, J. P., Sowers, T., Brook, E. J., Alley, R. B., and Bender, M. L.: Timing of abrupt climate change at the end of the Younger Dryas interval from thermally fractionated gases in polar ice, *Nature*, 391, 141–146, 1998.

Severinghaus, J. P. and Brook, E. J.: Abrupt Climate Change at the End of the last Glacial
25 Period Inferred from Trapped Air in Polar Ice, *Science*, 286, 930–924, 1999.

Severinghaus, J. P., Grachev, A., Luz, B., and Caillon, N.: A method for precise measurement of argon 40/36 and Krypton/Argon ratios in trapped air in polar ice with applications to past firn thickness and abrupt climate change in Greenland and at Siple Dome, Antarctica, *Geochemi. Cosmochemi. Ac.* 67, 325–343, 2003.

30 Singleton, J. H.: Interaction of oxygen with hot tungsten, *J. Chem. Phys.*, 45, 2819–2826, 1966.
Sowers, T. A., Bender, M. L., and Raynaud, D.: Elemental and isotopic composition of occluded O₂ and N₂ in polar ice, *J. Geophys. Res.*, 94, 5137–5150, 1989.

Taylor, K. C., White, J. W. C., Severinghaus, J. P., Brook, E. J., Mayewski, P. A., Alley, R. B.,

Steig, E. J., Spencer, M. K., Meyerson, E., Meese, D. A., Lamorey, G. W., Grachev, A., Gow, A. J., and Barnett, B. A.: Abrupt climate change around 22 ka on the Siple Coast of Antarctica, *Quaternary Sci. Rev.*, 23, 7–15, 2004.

CPD

4, 149–171, 2008

**An improved method
for delta ^{15}N
measurements**

F. S. Mani et al.

Title Page

Abstract

Introduction

Conclusions

References

Tables

Figures

◀

▶

◀

▶

Back

Close

Full Screen / Esc

Printer-friendly Version

Interactive Discussion



Table 1. Review of studies utilizing $\delta^{15}\text{N}$ in characterising abrupt climate changes in Greenland and Antarctic ice cores.

Location	Climate Event	Reference
Greenland Ice Cores		
GISP2 ^a	Termination of the Younger Dryas	Severinghaus et al., 1998
GRIP ^b	The Bølling transition	Severinghaus and Brook, 1999
	8.2 Kyr event	Leuenberger et al., 1999
	DO ^c 19	Lang et al., 1999
	DO 12	Landais et al., 2004a
NorthGRIP	DO 19	Landais et al., 2004b
	DO 18, 19, 20	Landais et al., 2004c
	DO 23 and 24	Landais et al., 2006a
	DO 9–17	Huber et al., 2006
West Greenland Ice margin	The last glacial termination from a horizontal ice core	Petrenko et al., 2006
Antarctic Ice cores		
DSS ^d	LGM ^f transition	Landais et al., 2006b
EDML ^e		
Vostok	The MIS ^g 5d/5c transition	Caillon et al., 2001
Siple Dome	2 rapid climatic events during the termination of the LGM	Severinghaus et al., 2003
	Abrupt climate change around 22 000	Taylor et al., 2004

^a Greenland Ice Sheet Project 2

^b Greenland Ice Core Project

^c Dansgaard Oeschger event

^d Dome South Summit ice core from Law Dome

^e EPICA Dronning Maud Land

^f Last Glacial Maximum

^g Marine Isotopic Stage

An improved method for delta ¹⁵N measurements

F. S. Mani et al.

Title Page

Abstract

Introduction

Conclusions

References

Tables

Figures



Back

Close

Full Screen / Esc

Printer-friendly Version

Interactive Discussion



An improved method for delta ^{15}N measurements

F. S. Mani et al.

Table 2. $\delta^{15}\text{N}$ of firn air samples (0 m and 12 m) measured on different days.

Firn Sample	Date of Analysis	$\delta^{15}\text{N}$ (‰)	Average	1σ
0 m	15/09/2006	0.003	0.004	0.002
	21/03/2007	0.004		
	02/04/2007	0.006		
12 m	28/09/2006	0.105	0.096	0.008
	21/03/2007	0.095		
	31/03/2007	0.089		

Title Page

Abstract

Introduction

Conclusions

References

Tables

Figures

◀

▶

◀

▶

Back

Close

Full Screen / Esc

Printer-friendly Version

Interactive Discussion



An improved method for delta ¹⁵N measurements

F. S. Mani et al.

Table 3. Illustrates the effect of oxygen in samples on $\delta^{15}\text{N}$ measurements.

Date	$\delta^{15}\text{N}$ measured with O ₂ removed	$\delta^{15}\text{N}$ measured with O ₂ present
19/03/2007	0.828±0.006	1.703±0.007
	0.822±0.008	1.884±0.016
	0.830±0.004	1.771±0.015
21/03/07	0.793±0.001	1.661±0.018
	0.794±0.007	1.611±0.080

Air samples were collected in six different vials simultaneously on 19 March 2007, of which three were processed through the hot copper furnace at 600°C, and three were processed through the copper furnace at room temperature. All samples were passed through the glass trap at –196 K to remove CO₂. Another suite of four air samples were collected on 21 March 2007 and were subjected to the same treatment.

Title Page

Abstract

Introduction

Conclusions

References

Tables

Figures

◀

▶

◀

▶

Back

Close

Full Screen / Esc

Printer-friendly Version

Interactive Discussion



An improved method for delta ^{15}N measurements

F. S. Mani et al.

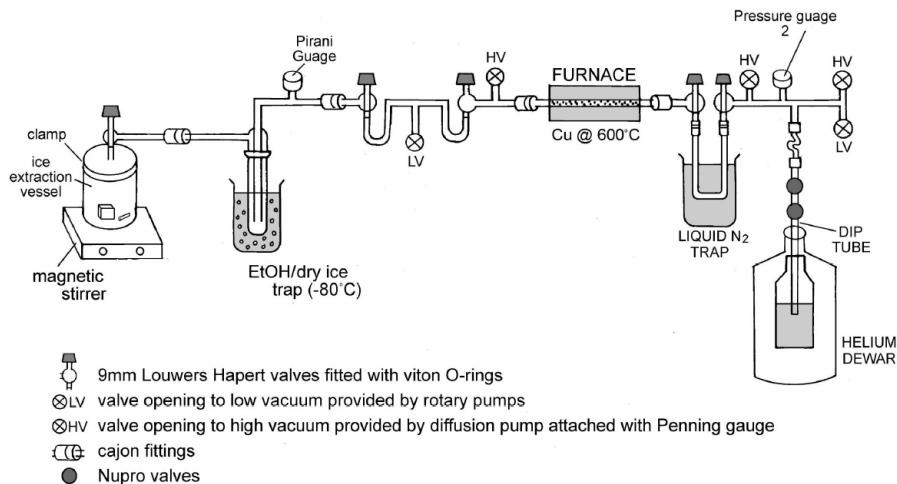

Fig. 1. Schematic of the extraction line (not drawn to scale).

Title Page

Abstract

Introduction

Conclusions

References

Tables

Figures



Back

Close

Full Screen / Esc

Printer-friendly Version

Interactive Discussion



**An improved method
for delta ¹⁵N
measurements**F. S. Mani et al.

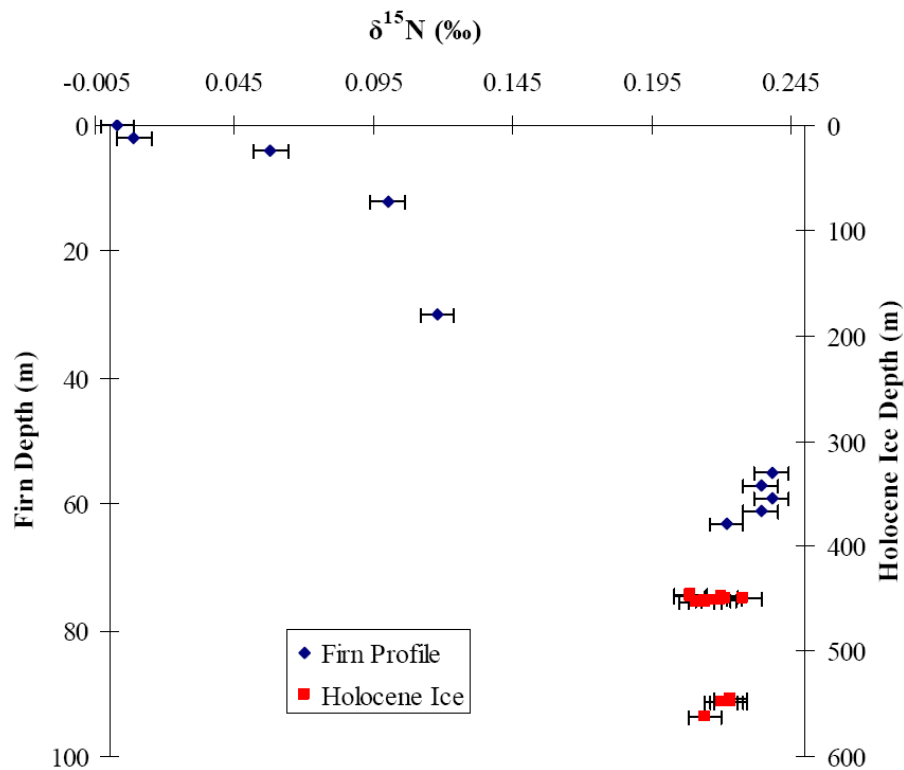

Fig. 2. $\delta^{15}\text{N}$ profile for Berkner Island firn Air and Holocene ice. The firn profile obtained is comparable to published firn data (Landais et al., 2006b).

[Title Page](#)[Abstract](#)[Introduction](#)[Conclusions](#)[References](#)[Tables](#)[Figures](#)[◀](#)[▶](#)[◀](#)[▶](#)[Back](#)[Close](#)[Full Screen / Esc](#)[Printer-friendly Version](#)[Interactive Discussion](#)

**An improved method
for delta ^{15}N
measurements**F. S. Mani et al.

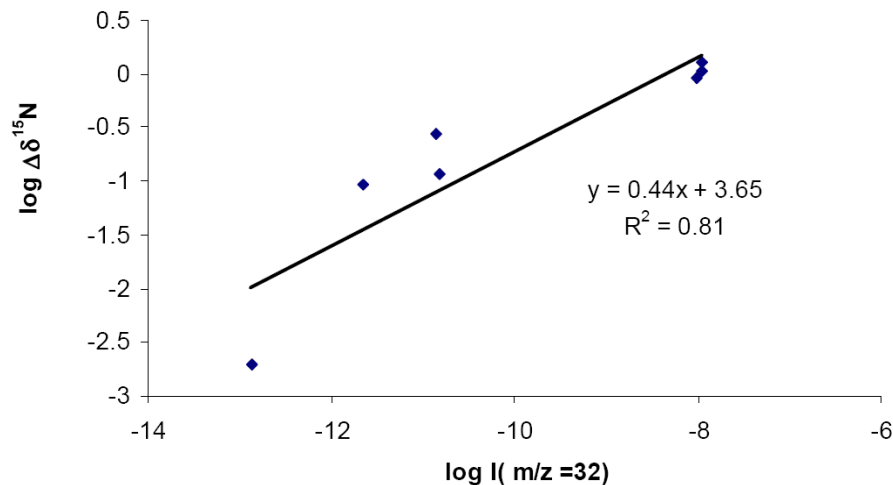

Fig. 3. A log – log plot of the change in $\delta^{15}\text{N}$ ($\Delta\delta^{15}\text{N}$) with intensity of the measured oxygen signal. The results show that small amounts of oxygen lead to changes in measured $\delta^{15}\text{N}$ composition. The gradient of 0.44 is close to that expected for the reaction $\text{C} + 1/2\text{O}_2 \rightarrow \text{CO}$ in the source of the mass spectrometer.

[Title Page](#)[Abstract](#)[Introduction](#)[Conclusions](#)[References](#)[Tables](#)[Figures](#)[◀](#)[▶](#)[◀](#)[▶](#)[Back](#)[Close](#)[Full Screen / Esc](#)[Printer-friendly Version](#)[Interactive Discussion](#)

**An improved method
for delta ^{15}N
measurements**F. S. Mani et al.

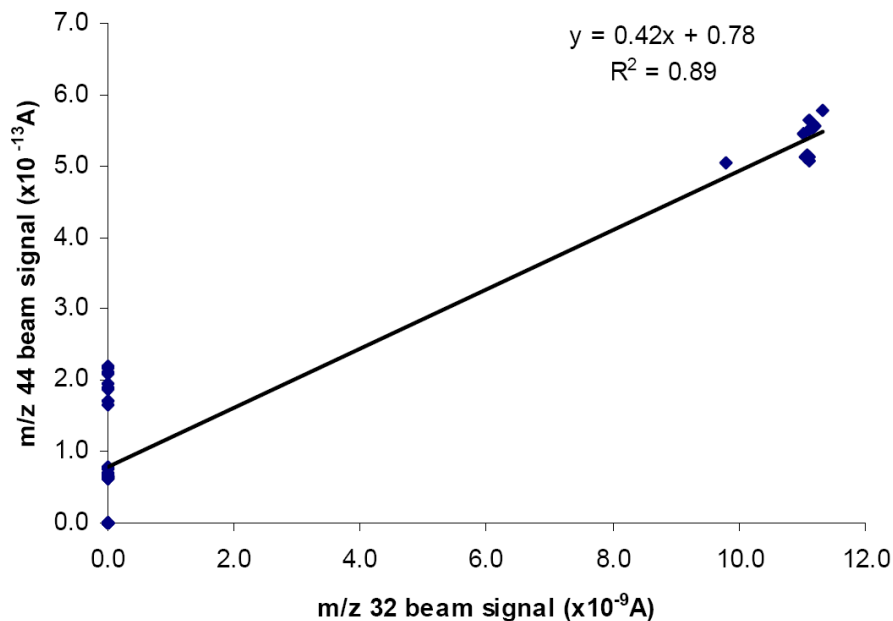

Fig. 4. An illustration of mass 32 and mass 44 correlations indicating that the presence of oxygen could potentially lead to in situ CO_2 production.

[Title Page](#)[Abstract](#)[Introduction](#)[Conclusions](#)[References](#)[Tables](#)[Figures](#)[◀](#)[▶](#)[◀](#)[▶](#)[Back](#)[Close](#)[Full Screen / Esc](#)[Printer-friendly Version](#)[Interactive Discussion](#)